



CHAPTER 8

Feedback

Go Ahead... Leave Feedback!



8 Feedback

Why Feedback?

- Desensitize the gain: make the value of the gain less sensitive to variations in the value of circuit components, such as might be caused by changes in temperature
- Reduce nonlinear distortion: make the output proportional to the input
- Reduce the effect of noise: minimize the contribution to the output of unwanted electric signals generated, either by the circuit components themselves, or by extraneous interference
- Control the input and output impedances: raise or lower the input and output impedance by the selection of an appropriate feedback topology
- Extend the bandwidth of the amplifier

8 Feedback

8.1 The General Feedback Structure

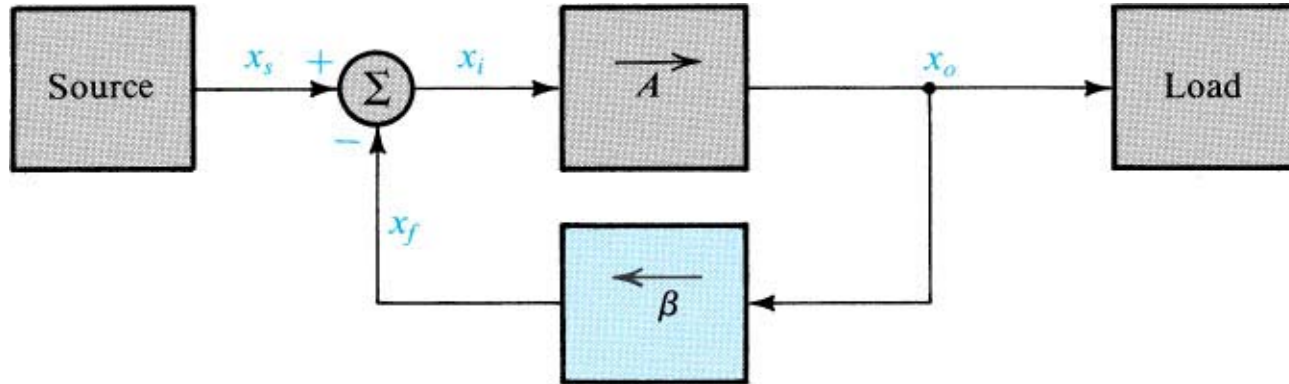

$$A_f \equiv \frac{x_o}{x_s} = ?$$

$$x_o = Ax_i$$

$$x_f = \beta x_o$$

$$x_i = x_s - x_f$$

$$A_f \equiv \frac{x_o}{x_s} = \frac{A}{1 + A\beta}$$

8.2 Some Properties of Negative Feedback

8.2.1 Gain Desensitivity

$$A_f \equiv \frac{x_o}{x_s} = \frac{A}{1 + A\beta}$$

Assume β is constant. Taking differentials of both sides results in

$$\frac{\partial A_f}{\partial A} = \frac{\partial A}{(1 + A\beta)^2} \qquad A_f = \frac{A}{1 + A\beta}$$

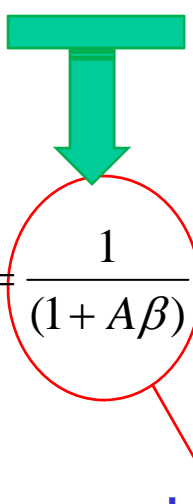
$$\frac{\partial A_f}{A_f} = \frac{1}{(1 + A\beta)} \frac{\partial A}{A}$$

desensitivity factor

8.2 Some Properties of Negative Feedback

8.2.2 Bandwidth Extension

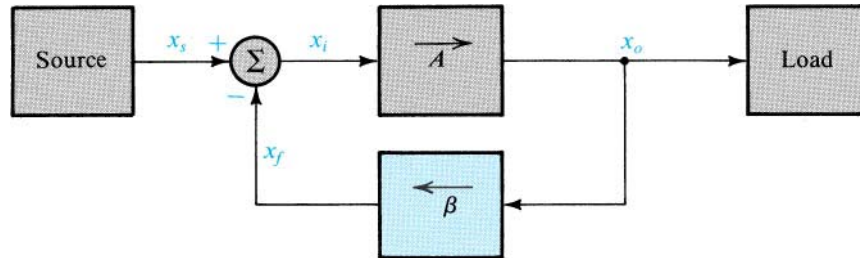

$$A(s) = \frac{A_M}{1 + s / \omega_H}$$

$$A_f(s) = \frac{A(s)}{1 + \beta A(s)}$$

$$A_f(s) = \frac{A_M / (1 + A_M \beta)}{1 + s / \omega_H (1 + A_M \beta)}$$

Midband Gain:

$$A_M \rightarrow \frac{A_M}{1 + A_M \beta}$$

3-dB Frequency:

$$\omega_H \rightarrow \omega_H (1 + A_M \beta)$$

8.2 Some Properties of Negative Feedback

8.2.3 Noise Reduction

Signal-to-Noise Ratio

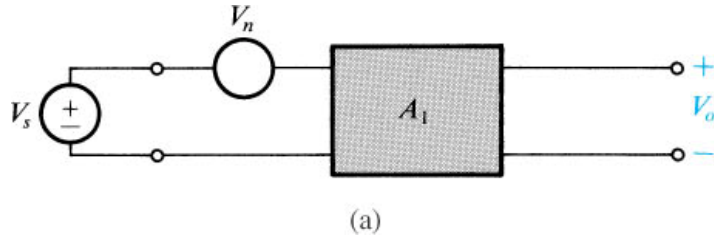

$$S / N = \frac{V_s}{V_n}$$

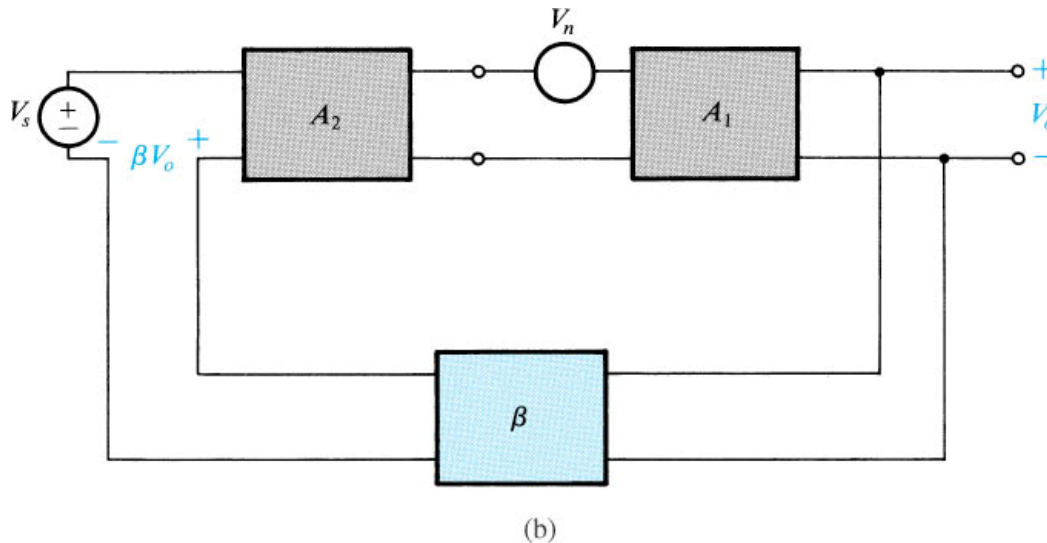

$$V_o = V_s \frac{A_1 A_2}{1 + A_1 A_2 \beta} + V_n \frac{A_1}{1 + A_1 A_2 \beta}$$

$$S / N = \frac{V_s}{V_n} A_2$$

8.2 Some Properties of Negative Feedback

8.2.3 Reduction in Nonlinear Distortion

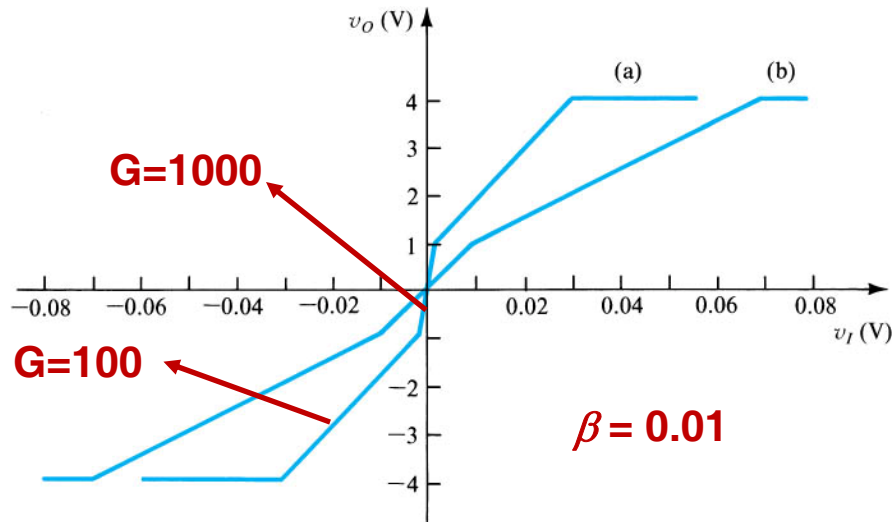

Open Gain: 1000 $A_{f1} = \frac{1000}{1 + 1000 \times 0.01} = 90.0$

Open Gain: 100 $A_{f2} = \frac{100}{1 + 100 \times 0.01} = 50$

Homework:

8.1, 8.4, 8.11, 8.14, 8.21, 8.24, 8.27, 8.28